



2065844705

Order no. P206 0266 13 Part no. 206 584 47 05
Edition B-2023



C-Class

Mercedes-AMG Supplement

Mercedes-Benz



Publication details

Internet

Further information about Mercedes-Benz vehicles and about Mercedes-Benz AG can be found on the following websites:

<https://www.mbusa.com> (USA only)

<https://www.mercedes-benz.ca> (Canada only)

Documentation team

©Mercedes-Benz AG: Not to be reprinted, translated or otherwise reproduced, in whole or in part, without written permission from Mercedes-Benz AG.

Vehicle manufacturer

Mercedes-Benz AG

Mercedesstraße 120

70372 Stuttgart

Germany

As at 31.01.22

Thank you for purchasing a Mercedes-AMG

Before your first drive, please read this Operator's Manual carefully and familiarize yourself with your vehicle. For your own safety and a longer service life of the vehicle, follow the instructions and warning notices in this Operator's Manual. Disregarding them may lead to damage to the vehicle or injury to people.

Damage to the vehicle resulting from the disregard of the instructions is not covered by the Mercedes-Benz Limited warranty.

The standard equipment and product description of your vehicle may vary and depends on the following factors:

- Model
- Order
- National version
- Availability

Your vehicle may therefore differ from that shown in the descriptions and illustrations in individual cases.

Mercedes-AMG reserves the right to introduce changes in the following areas:

- Design
- Equipment
- Technical features

The following documents are integral parts of the vehicle:

- Digital operator's manual
- Printed Operator's Manual
- Maintenance Booklet
- Supplementary manuals relating to specific equipment
- Supplementary documents

Keep these documents in the vehicle at all times. Ensure that all documents are in the vehicle or passed on in the event of sale or rental.

Mercedes-Benz USA, LLC

Mercedes-Benz Canada, Inc.

A Mercedes-Benz Group AG Company

2065844705



Symbols	3	Overview of status displays on the driver's display	23	Display messages and warning/indicator lamps	36
At a glance	4	Notes on radio reception	25	Display messages	36
Cockpit	4	AMG TRACK PACE	25	Warning and indicator lamps	38
General notes	6	Maintenance and care	30	Index	40
Operator's Manual	6	Notes on the care of tailpipes	30		
Occupant safety	7	Breakdown assistance	31		
Seat belts	7	Removing the warning triangle	31		
Driving and parking	8	Wheels and tires	32		
Driving	8	Changing a wheel	32		
DYNAMIC SELECT button	10	Technical data	33		
Automatic transmission	13	Operating fluids	33		
Driving and driving safety systems	15	Vehicle data	35		
Driver's display	21				
Operating the driver's display	21				
Driver display menus	22				

In this operator's manual, you will find the following symbols:

⚠ WARNING Danger due to failure to observe the warning notices

Warning notices draw your attention to hazards that may endanger your health or life, or the health or life of others.

▶ Observe the warning notices.

🌿 ENVIRONMENTAL NOTE Environmental damage due to failure to observe environmental notes

Environmental notes include information on environmentally responsible behavior or environmentally responsible disposal.

▶ Observe environmental notes.

! NOTE Damage to property due to failure to observe notes on material damage

Notes on material damage inform you of risks which may lead to your vehicle being damaged.

▶ Observe notes on material damage.

ⓘ Useful instructions or further information that could be helpful to you.

▶ Instruction

(→ page) Further information on a topic

Display Display in the central display

↪ Highest menu level, which is to be selected in the multimedia system

➤➤ Relevant submenus, which are to be selected in the multimedia system

* Indicates a cause

4 At a glance – Cockpit

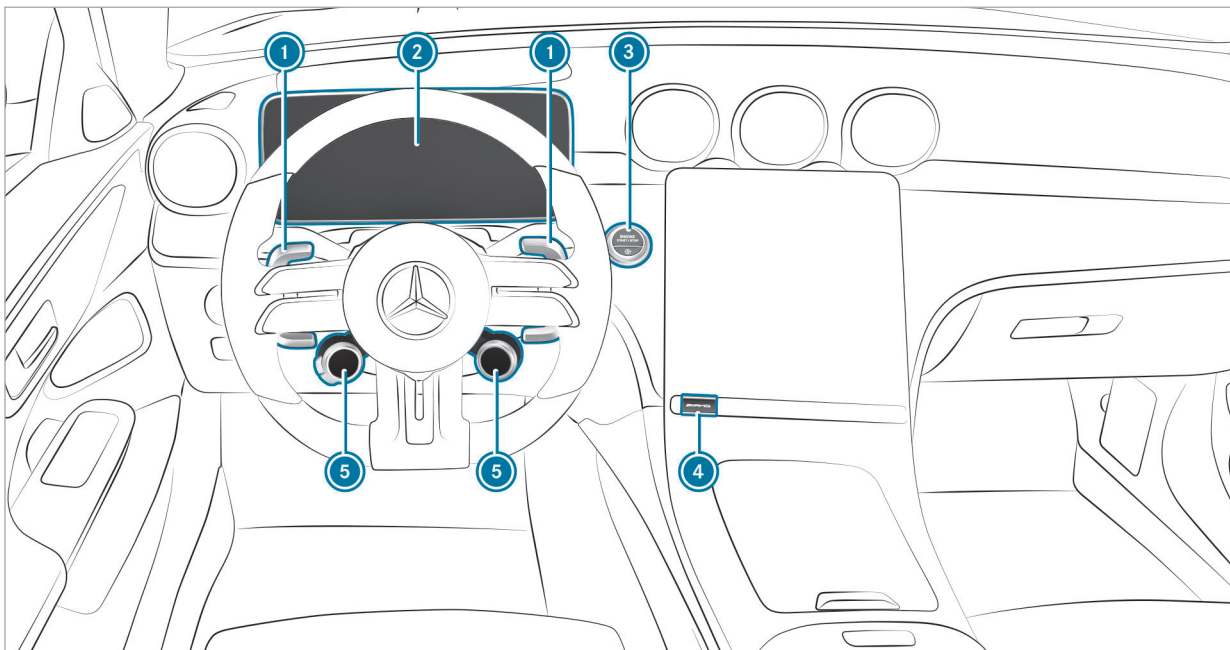

Left-hand-drive vehicles

①	Steering wheel paddle shifters	→	13	④	Sets AMG DYNAMIC SELECT in the MBUX multimedia system	→	12
②	Driver's display			⑤	AMG steering-wheel buttons	→	8
③	 Start/stop button	→	9				

Operator's Manual

These Operating Instructions provide information on all the important functions of your AMG vehicle that are either not described or differ from the descriptions in the Operator's Manual. This information supplements or replaces the corresponding sections in the vehicle Operator's Manual. Under no circumstances do the Operating Instructions replace the printed vehicle Operator's Manual and the Digital Operator's Manual in the vehicle.

This Supplement and the Digital Operator's Manual in the vehicle describe the following models, standard and special equipment of your vehicle:

- Models, standard and special equipment available at the time of going to press with these Operating Instructions.
- The models and the standard and special equipment only available in certain countries.
- The models and the standard and special equipment, which will only be available at a later date.

Note that your vehicle may not be installed with all features described. This is also the case for systems relevant to safety. Therefore, the equipment on your vehicle may differ from that in the descriptions and illustrations.

The original purchase agreement for your vehicle contains a list of the equipment in your vehicle at the time of delivery.

Should you have any questions concerning equipment and operation, please consult an authorized Mercedes-Benz Center.

The Operator's Manual, Operating Instructions, further supplementary documents and Maintenance Booklet are important documents and should be kept in the vehicle.

Seat belts

Limitations of the protection provided by the seat belt

The AMG sports seat and the AMG Performance seat are designed for the standard three-point seat belt. If you install a different multipoint seat belt, for example a four-point seat belt, the restraint system cannot provide the intended level of protection.

Depending on the type of vehicle, there may be openings in the seat backrest. These openings have no function.

⚠ WARNING Risk of injury or fatal injury due to modified seat belt systems

If you feed seat belts through the opening in the seat backrest, the seat backrest may be damaged or may even break in the event of an accident.

- ▶ Only use the standard three-point seat belt.
- ▶ Never modify the seat belt system.

Driving

Function of the AMG steering-wheel buttons

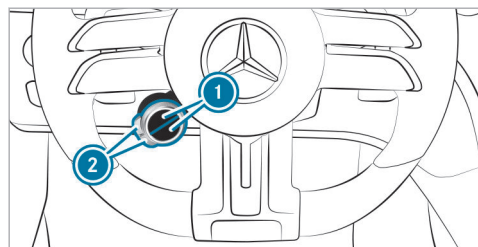







The AMG steering-wheel buttons are an additional control element with two buttons on the steering wheel.

You can assign two vehicle functions of your choice to the control element. You can between the available functions for corresponding button ② by pressing the upper or lower sections of display buttons ① repeatedly. Display buttons ① will show each function selected.

The following functions are available:

 ESP® (→ page 15)

-  AMG RIDE CONTROL (→ page 19)
-  Manual gearshifting (→ page 13)
-  ECO start/stop function (→ page 9)
-  AMG Real Performance Sound (→ page 10)
-  Camera views (see the vehicle Operator's Manual)
-  AMG Dynamics (→ page 10)

i Individual functions may not be shown. How functions are displayed and the order in which they are displayed can be set in the multimedia system (→ page 8).

If you have assigned a function to one of display buttons ①, you can operate this function with corresponding button ②.

The assignment of display buttons ① will remain stored even after the vehicle is started again. The operating status of the respective function will, however, be reset to the basic setting.

Setting the AMG steering wheel buttons

Multimedia system:

-  ➤ Settings ➤ System
- Control Elements
- AMG Steer. Wheel Buttons

i The **SETTINGS SELECT** menu can also be called up using the AMG button in the center console or by pressing and holding the respective display button.

The left display buttons on the steering wheel can be set in the **SETTINGS SELECT** menu.

- Select the upper or lower display button in the central display and switch to editing mode by pressing and holding it.
 - Press  and select the desired function from the list.
- The selected function is assigned to the corresponding display button and can now be called up directly by simply pressing it.

Deleting button assignment

- ▶ Select the upper or lower display button and switch to editing mode by pressing and holding it.
- ▶ Press  to delete the selected display button assignment.

Function of the Emotion Start (Mercedes-AMG vehicles)

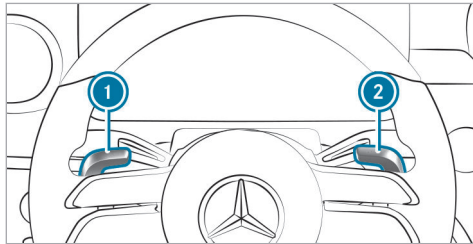

- ▶ Start the vehicle with the start/stop button and simultaneously pull one of steering wheel paddle shifters ① or ②. The idle speed is briefly increased upon starting and the engine sound is reproduced in a sporty and powerful manner.

Follow the instructions for starting the vehicle in the operator's manual for the vehicle.

Switching the ECO start/stop function on or off using the steering wheel button (Mercedes-AMG vehicles)

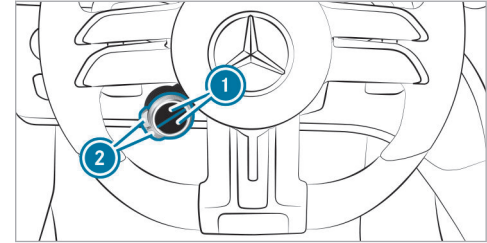

Observe the notes on the ECO start/stop function in the vehicle Operator's Manual.

- ① **Plug-in hybrid:** the ECO start/stop function is not available.
- ① You can also switch the ECO start/stop function on or off via the multimedia system.



- ▶ Press upper or lower display button ① repeatedly, until it displays the  symbol.
- ① If the display button does not show the symbol, then it is hidden. How functions are displayed and the order in which they are displayed can be set in the multimedia system (→ page 8).
- ▶ Press corresponding button ②.

The symbol indicates the current status of the ECO start/stop function:

-  (red): deactivated
-  (green): activated
-  (yellow): inactive

AMG Real Performance Sound

Selecting a sound characteristic with the steering-wheel button

- i** You can select a comfortable (Balanced) or a sporty (Powerful) sound characteristic using the steering-wheel button or the multimedia system (→ page 12).

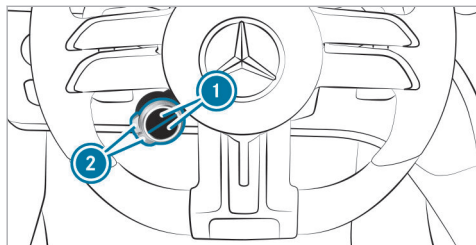

- ▶ Press upper or lower display button **1** repeatedly, until it displays the  symbol.

- i** If the display button does not show the symbol, then it is hidden. How functions are displayed and the order in which they are displayed can be set in the multimedia system (→ page 8).

played can be set in the multimedia system (→ page 8).

- ▶ Press corresponding button **2**.

The color of the button symbol indicates the currently selected sound characteristic:

- **Blue:** Balanced – comfortable
- **Red:** Powerful – sporty





DYNAMIC SELECT button

Function of the DYNAMIC SELECT button (Mercedes-AMG vehicles)



- i** Depending on the engine and equipment, the vehicle has different drive programs.

Use the DYNAMIC SELECT button to change between the following drive programs:

-  **Slippery**
 - Optimized pulling away and driving characteristics in wintry and slippery road conditions
-  **Comfort**
 - Comfortable and economical driving

-  **Individual**
 - Customized settings for drive, suspension, steering and ESP®
-  **Sport**
 - Sporty driving
-  **Sport+**
 - Particularly sporty driving
-  **Race**
 - Maximum sportiness
 - Particularly firm suspension tuning
 - Sporty sound from the exhaust system

- i** The  drive program is available only for the **Mercedes-AMG C 63 S E Performance** model and vehicles with the **AMG DYNAMIC PLUS package**.

The  drive program offers driving characteristics suited to the racetrack and must not be used on normal roads. The  drive program may be activated and used only on dedicated race circuits, not on public roads.

Mercedes-AMG recommends selecting the  drive program when in city traffic or stop-and-go traffic.

Depending on the drive program selected, the following vehicle characteristics will change:



- Drive
- AMG Dynamics
 - The four agility functions, Basic, Advanced, Pro and Master, will be selected automatically depending on the drive program.
 - The steering, shift timing point, all-wheel drive and stabilization functions will be adapted to the selected drive program.
 - When ESP[®] is activated, the Pro agility function will be selected in the  drive program. The Master function will be selected automatically when ESP[®] is deactivated.
- Real Performance Sound
- Suspension
- Steering

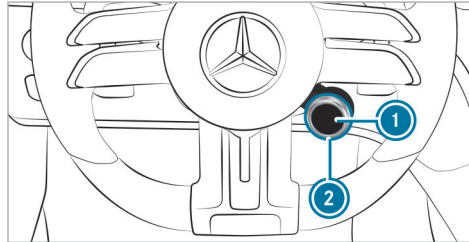

- ❗ You can call up vehicle characteristics via the Performance menu on the on-board computer.
- ❗ You can adjust the agility functions of AMG Dynamics using the AMG steering-wheel buttons.

Selecting a drive program (Mercedes-AMG vehicles)

Selection with right-hand steering-wheel button



- ▶ Turn the rotary switch . The selected drive program will appear on display button  and on the driver's display.

- ❗ Individual drive programs may not be shown. How drive programs are displayed and the order in which they are displayed can be set in the multimedia system (→ page 12).
- ▶ To select the  drive program directly: press display button .

Selection via the central display (multimedia system)

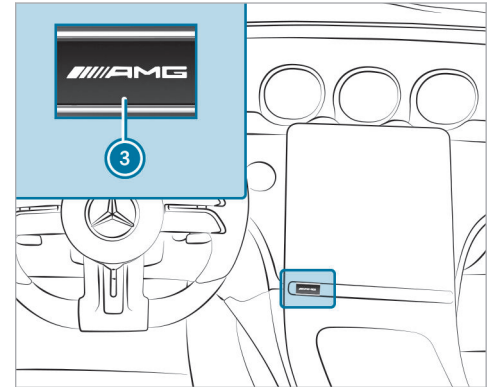

- ▶ Press button  and select the drive program via the central display (→ page 12).

Configuring DYNAMIC SELECT (multimedia system)

Multimedia system:

→  ▶ Settings ▶ Vehicle
▶ DYNAMIC SELECT

Setting drive program I

- ▶ Select  Individual.
- ▶ Select and set a category.

Switching the reset display on/off

- ▶ Switch Request at Start on or off.
- ⓘ This function must be activated for each user profile separately. Only when this function is activated will the drive program and ECO start/stop setting for the previous journey be saved for the respective user profile.

Function on: the next time the vehicle is started a prompt appears asking whether the last active drive program should be restored. If the ECO

start/stop function was deactivated, an additional prompt appears asking if the function should remain deactivated.

- ⓘ The prompt only appears if the previously active settings deviate from the standard settings.

Function off: the next time the vehicle is started the  drive program is set automatically. The ECO start/stop function is activated automatically.

Setting AMG DYNAMIC SELECT in the MBUX multimedia system

Multimedia system:

→  ▶ Settings ▶ Vehicle
▶ DYNAMIC SELECT

Overview of the AMG DYNAMIC SELECT menu

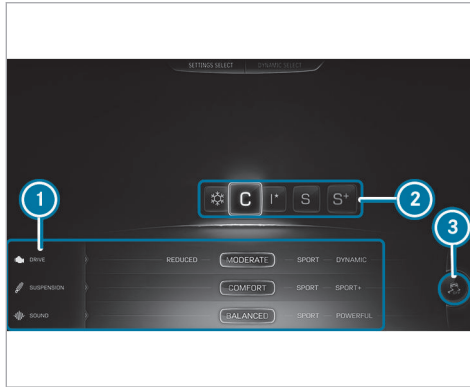

① AMG drive program settings

② Drive programs

③ ESP® (→ page 15)

① Depending on the equipment, the AMG menu **DYNAMIC SELECT** can also be called up using the AMG button in the center console.

▶ Select the appropriate drive program.

The settings of the drive programs can be adjusted individually.

▶ Select the desired tab on the left and make the relevant setting.

Setting options for the drive programs

- Drive:
Reduced/Moderate/Sport/Dynamic
- AMG DYNAMICS:
Basic/Advanced/Pro
- Suspension:
Comfort/Sport/Sport+
- Sound:
Balanced/Sport/Powerful

Automatic transmission

Rocking the vehicle free

Rocking the vehicle free may help to free the vehicle if it has become stuck in slush or snow.

To rock the vehicle free, move the DIRECT SELECT lever upwards and downwards past the point of resistance to switch between transmission positions **D** and **R**.

① The maximum design speed for switching between **D** and **R** is 6 mph (9 km/h).

Manual shifting (Mercedes-AMG vehicles)

① You can also activate and deactivate manual gearshifting via the multimedia system (→ page 14).

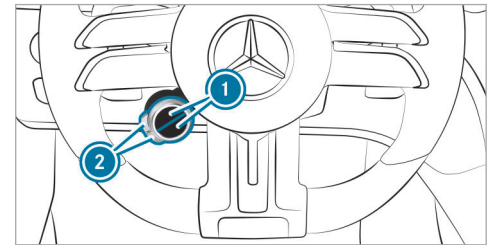



▶ Press upper or lower display button ① repeatedly until it displays the  symbol.

i If the display button does not show the symbol, then it is hidden. How functions are displayed and the order in which they are displayed can be set in the multimedia system (→ page 8).

▶ **To activate/deactivate:** press the corresponding button **2**.

The symbol indicates the currently selected transmission position:

-  M (red): manual gearshifting
-  D (blue): automatic transmission

Shifting up and down

I **NOTE** Damage to the engine due to shifting up too late

The automatic transmission does not shift up in manual mode even when the engine's limiting speed is reached.

The fuel supply is interrupted in order to prevent the engine from overrevving.

▶ Shift up before the engine speed reaches the red area in the tachometer.

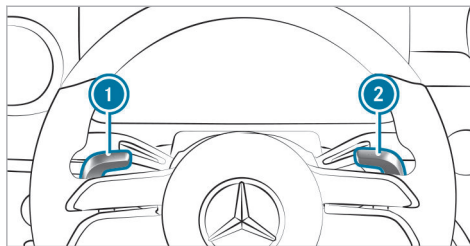

▶ **To shift up:** pull steering wheel paddle shifter **2**.

▶ **To shift down:** pull steering wheel paddle shifter **1**.

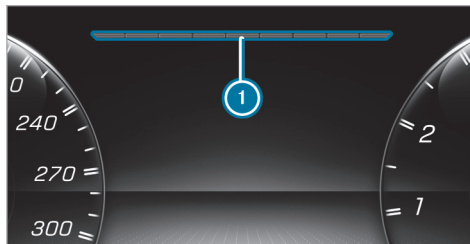

If the engine speed is too high or too low, you will not be able to change gear using the steering wheel paddle shifters. In this case, segments **1** will light up red.

Permanently activating or deactivating manual gearshifting

Multimedia system:

▶  ▶ Settings ▶ Vehicle ▶ Driving

▶ Permanently switch the function on or off.

Function of glide mode (Mercedes-AMG vehicles)

With an anticipatory driving style, Glide mode helps you to reduce fuel consumption. When driving in Glide mode, the  symbol will appear on the driver's display.

Glide mode is activated if the following conditions are met:

- The ECO start/stop function is switched on.
- Drive program  is selected with the drive setting "Moderate" or "Reduced".
- The speed is within a suitable range.

- The road's course is suitable, e.g. no steep uphill or downhill inclines or tight bends.
- The state of charge of the battery is sufficient.
- You are no longer depressing the accelerator or brake pedal.

Glide mode is deactivated again if one of the conditions is no longer met.

Driving and driving safety systems

Function of ESP® (Mercedes-AMG vehicles)

You can select between the following modes of the Electronic Stability Program (ESP®):

- ESP® ON
- ESP® SPORT
- ESP® OFF

Characteristics when ESP® is activated

ESP® monitors and improves driving stability and traction, especially in the following situations:

- When pulling away on wet or slippery roads.
- When braking.

- When there is a strong crosswind and the vehicle is traveling at a speed between approximately 47 mph (75 km/h) and 125 mph (200 km/h).

ESP® can stabilize the vehicle by intervening in the following ways:

- One or more wheels are braked.
- The engine output is adapted according to the situation.

ESP® is activated every time the vehicle is started regardless of whether ESP® was in ESP® SPORT or deactivated before the vehicle was switched off.

When the ESP® warning lamp  flashes, one or more wheels have reached their grip limit:



- Adapt the driving style to suit the prevailing road and weather conditions.
- Do not deactivate ESP® under any circumstances.
- Only depress the accelerator pedal as far as necessary.

Characteristics of ESP® SPORT

⚠ WARNING Risk of skidding if ESP® SPORT is used incorrectly

When you activate ESP® SPORT, there is an increased risk of skidding and having an accident.

▶ Activate ESP® SPORT only in the circumstances described below.

When ESP® SPORT is selected, the  and  warning lamps light up continuously.

Select ESP® SPORT when the vehicle's own oversteering and understeering characteristics are desired, e.g. on specially designated roads.

Driving with ESP® SPORT or with ESP® deactivated requires an extremely qualified and experienced driver.

If ESP® SPORT is activated and one or more wheels start to spin, the ESP® warning lamp  flashes. ESP® then stabilizes the vehicle only to a limited degree.

ESP® SPORT also has the following characteristics:



- ESP® improves driving stability only to a limited degree.
- ETS/4ETS traction control is still active.
- The engine's torque is restricted only to a limited degree and the driven wheels can spin.
The spinning of the wheels results in a cutting action for better traction on loose surfaces.
- ESP® continues to provide assistance when the brakes are firmly applied.
- Crosswind Assist is no longer active.

Characteristics when ESP® is deactivated

⚠ WARNING Risk of skidding if ESP® is deactivated

If you deactivate ESP®, ESP® cannot carry out vehicle stabilization.

- ▶ ESP® should only be deactivated in the following situations.

When ESP® is deactivated, the  and  warning lamps light up continuously.

Deactivating ESP® has the following effects:

- Driving stability will no longer be improved.
- The driven wheels could spin.
- ETS/4ETS traction control is still active.
- Crosswind Assist is no longer active.

i Even when ESP® is deactivated, you are still assisted by ESP® when braking hard.

It may be best to activate ESP® SPORT or deactivate ESP® in the following situations:

- When using snow chains.
- In deep snow.
- On sand or gravel.

i Spinning the wheels results in a cutting action, which enhances traction.

i Activate ESP® as soon as the situations described above no longer apply. ESP® will otherwise not be able to stabilize the vehicle if the vehicle starts to skid or a wheel starts to spin.

If the ESP® warning lamp  lights up continuously, ESP® is not available due to a malfunction.

Observe the display messages, warning lamps and indicator lamps that are shown.

- Indicator and warning lamps
- Display messages

ETS/4ETS (Electronic Traction System)

ETS/4ETS traction control is part of ESP®.

ETS/4ETS can improve the vehicle's traction by intervening in the following ways:

- The driven wheels are braked individually if they spin.
- More drive torque is transferred to the wheel or wheels with traction.

Setting ESP® with the steering-wheel button

i You can also set ESP® via the multimedia system (→ page 17).

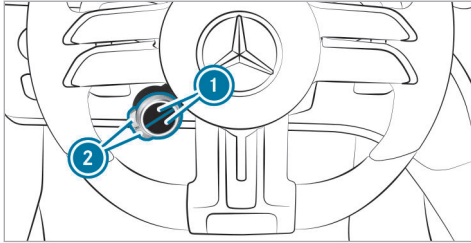

▶ **To set ESP®:** press upper or lower display button ① repeatedly, until it displays the symbol.

ⓘ If the display button does not show the symbol, then it is hidden. How functions are displayed and the order in which they are displayed can be set in the multimedia system (→ page 8).

The lane color of the button symbol indicates the current setting:

- (blue): ESP® ON
- (yellow): ESP® SPORT
- (red): ESP® OFF

▶ **To set ESP® SPORT:** briefly press button ② when ESP® is activated. The road in the button symbol lights up yellow.

The and warning lamps appear in the driver's display.

▶ **To deactivate ESP®:** select ESP® SPORT and then press and hold button ②. The road in the button symbol lights up red.

The and warning lamps appear in the driver's display.

ⓘ When you deactivate ESP® in the drive program, AMG Dynamics automatically switches to the **Master** level.

▶ **To activate ESP®:** briefly press button ② when ESP® SPORT is selected or ESP® is deactivated. The road in the button symbol lights up blue.

The and or warning lamps go out.

When the symbol is shown with a red ! on the display button, ESP® is malfunctioning. Observe the information on warning lamps and display messages which are shown in the driver's display.

Activating/deactivating ESP® (Electronic Stability Program)

Multimedia system:



▶ Select ESP.

▶ Select On or Off.

ESP® is deactivated if the ESP® OFF warning lamp lights up continuously in the driver's display.

Observe any information on warning lamps and display messages which may be shown in the driver's display.







Setting ESP® in the multimedia system



Multimedia system:

→  ► Settings ► Vehicle
► DYNAMIC SELECT

- ❶ Depending on the equipment, the AMG menu **DYNAMIC SELECT** can also be called up using the AMG button in the center console.

ESP® is always activated when the vehicle is started. The road in the  button symbol lights up blue.

- **To set ESP SPORT:** when ESP is activated, briefly press  to change to the **Sport** program. The road in the  button symbol lights up yellow.
- **To deactivate ESP®:** set the ESP® SPORT program and press and hold  to deactivate ESP®. The road in the  button symbol lights up red. The  and  warning lamps appear in the driver's display.

- **To activate ESP®:** briefly press  in ESP® SPORT or if ESP® is deactivated. The road in the  button symbol lights up blue.

The  and  or  warning lamps go out.

- ❶ You can also adjust ESP using the steering-wheel buttons (→ page 15)

RACE START

Information about RACE START

RACE START enables optimal vehicle acceleration from a standstill. A suitably high-grip road surface is required for this, and the tires and vehicle must also be in good condition.

- ❶ Use RACE START only after the vehicle has been run in.
- ❶ RACE START must not be used in normal road operation. RACE START may be activated and used only on dedicated race circuits, not on public roads. Read the safety notes and information on ESP® (→ page 15).

⚠ WARNING Risk of skidding and having an accident from wheels spinning



If you use RACE START, depending on the ESP® mode selected, there is an increased risk of skidding and having an accident.

- Make sure that no persons or obstacles are in the close vicinity of your vehicle.

Activating RACE START

Requirements:

- The vehicle is switched on and the transmission and the engine are at normal operating temperature.
- The driver's door is closed.
- The front wheels are in a straight-ahead position.
- The vehicle is on level ground.
- The vehicle is stationary, the brake pedal is depressed (left foot) and the parking brake is released.
- The transmission is in position **D**.

- One of drive programs ,  or  is selected (→ page 10).

▶ Rapidly depress the accelerator pedal fully. The engine speed will increase.

ⓘ If the activation conditions are not fulfilled, RACE START cannot be used. The **RACE START Not Possible See Operator's Manual** message appears in the driver's display.

▶ The **RACE START Release Brake to Start** message appears in the driver's display.

ⓘ In this phase, you can adjust RACE START depending on the road conditions: you can vary the engine speed by pulling on one of the steering wheel paddle shifters. The segments in the driver's display flicker rapidly.

ⓘ If the brake pedal is not released after a short while, RACE START will be canceled. The **RACE START Canceled** message appears in the driver's display.

▶ Take your foot off the brake, but keep the accelerator pedal depressed. The vehicle will pull away at maximum acceleration. The **RACE START Active** message appears in the driver's display.

RACE START will be deactivated immediately if you release the accelerator pedal during RACE START or if any of the activation conditions are no longer fulfilled. The **RACE START Canceled** message appears in the driver's display.

ⓘ After using it several times in quick succession, RACE START will be unavailable until a certain distance has been driven.

AMG adaptive sport suspension system

Function of AMG RIDE CONTROL

AMG RIDE CONTROL is an electronically controlled damping system for improved driving comfort and increased driving safety.

The damping is adjusted individually to each wheel and depends on the following factors:

- driving style, e.g. sporty
- road condition, e.g. bumps

- the individual selection of **SPORT**, **SPORT +** or **COMFORT**

The suspension setting depends on the engine speed.

In addition, you can select the setting in every drive program individually using the AMG steering-wheel button (→ page 19). After a drive program is changed, the automatic suspension setting of the drive program is reactivated.

ⓘ When the vehicle is started again, the **COMFORT** setting is activated automatically.

Selecting the suspension setting

ⓘ You can also adjust the suspension setting via the multimedia system (→ page 12).



You can select from three different suspension settings:

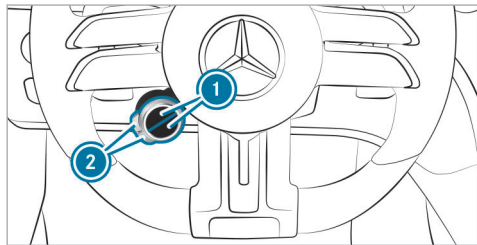

- **COMFORT** ensures a comfortable suspension setting. Select this suspension setting if you prefer a comfortable driving style.
- **SPORT** ensures a firmer suspension setting. Select this suspension setting when employing a sporty driving style, e.g. on winding country roads.

- **SPORT +** ensures a very firm suspension setting.



The  symbol indicates the currently selected mode:

-  (blue): COMFORT
-  (yellow): SPORT
-  (red): SPORT +

▶ Press the upper or lower  display button repeatedly, until it displays the  symbol.

 If the display button does not show the symbol, then it is hidden. How functions are displayed and the order in which they are displayed can be set in the multimedia system (→ page 8).

▶ Press corresponding button .
The selected suspension setting is shown in the driver's display as a message.

Operating the driver's display

⚠ WARNING Risk of distraction from information systems and communications equipment

If you operate information systems and communication devices integrated in the vehicle when driving, you could be distracted from the traffic situation. This could also cause you to lose control of the vehicle.

- ▶ Only operate this equipment when the traffic situation permits.
- ▶ If you cannot be sure of this, stop the vehicle whilst paying attention to road and traffic conditions and operate the equipment with the vehicle stationary.

Observe the legal requirements for the country in which you are currently driving when operating the driver's display.

Scrolling through the menu bar and calling up a menu

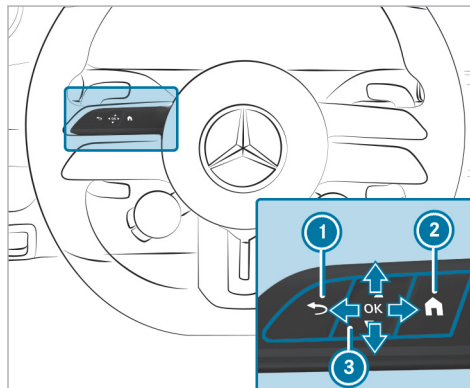

- ① Back button
- ② Main menu
- ③ Touch Control

The content on the driver's display is controlled using the control elements on the left side of the steering wheel. Touch Control ③ is used to navi-

gate in a vertical and horizontal direction by swiping with one finger. Confirm your selection by pressing the Touch Control.

- ① To operate Touch Control ③ in the most effective way, use the tip of your thumb if possible. You can also set the sensitivity of the Touch Control on the central display.
- ▶ Briefly press main menu button ②.
- ▶ Select a menu by swiping to the left or right on Touch Control ③.
- ▶ **To confirm:** press Touch Control ③.

Calling up or exiting the **Options** submenu

- ▶ **To call up:** press left-hand Touch Control ③.
- ▶ **To exit:** press back button ①.

Browsing through display content or lists

- ▶ Swipe up, down, left or right on left-hand Touch Control ③.
- ① For different menus, icons appear at the right edge of the center display section to indicate the current position in a list.

Setting display content as the standard display

You can set custom-configured menu display content as the standard display.

- ▶ Press and hold left-hand Touch Control **3** until the bar display that appears is completely filled. The **Set Shortcut?** prompt will appear.
 - ▶ Swipe left on left-hand Touch Control **3** and select **Yes**.
 - ▶ **To confirm:** press left-hand Touch Control **3**.
 - ▶ **To call up standard displays:** press back button **1** on the upper level of a menu.
- i** Pressing back button **1** on the standard display will call up the previous menu.

Resetting values

- ▶ **To call up the Options submenu:** press left-hand Touch Control **3**.
- ▶ **To select the function to be reset:** press left-hand Touch Control **3**.
- ▶ Select **Yes**.
- ▶ **To confirm:** press left-hand Touch Control **3**.

Driver display menus

Calling up the Track Pace menu

Driver's display:

➔ **TRACK PACE**

The Track Pace function is intended for use on designated race tracks. Do not use this function on public roads, and adapt your driving style to your personal capabilities and the ambient conditions.

The following options will be displayed on the **TRACK PACE** menu:

- G-meter
- Race track selected
- Braking and acceleration procedure
- Gear currently selected



Displays on the Track Pace menu (example)

- 1** G-meter
- 2** Center display content (example: gear display)
- 3** Telemetry display (example: selected race track)

- ▶ **To call up the menu:** press the left-hand Touch Control.

The display content of the **TRACK PACE** menu will adapt to the selected settings on the central display:

- Gear display
- Braking points
- Acceleration

- Quarter-miles
- Race track selected on the central display
- Current race
- Record route

While the vehicle is in motion, the G-meter shows the forces that are exerted on the vehicle occupants both laterally and in the direction of travel. The maximum values appear in red in the coordinate system.

Calling up displays on the Sport menu

Driver's display:

→ Sport

The **Sport** menu displays information about the engine data, the setup and the temperature of the vehicle.

- ▶ **To call up the menu:** swipe to the left or right on the left-hand Touch Control.
- ▶ **To confirm:** press Touch Control.

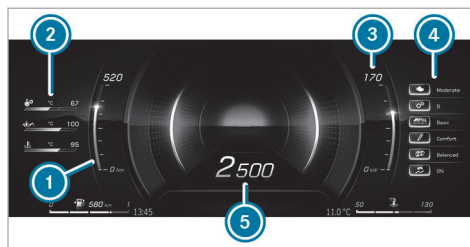







- 1 Current torque
 - 2 Temperature (transmission oil temperature, engine oil temperature, coolant temperature)
 - 3 Current power output
 - 4 Setup (drive position, transmission position, AMG DYNAMICS, suspension tuning, exhaust system, ESP®)
 - 5 Engine speed
- i Depending on the vehicle equipment, AMG-specific content regarding temperature, setup and engine data will be displayed. The settings for the setup display content can be configured either via the buttons on the multi-function steering wheel or via the MBUX mul-

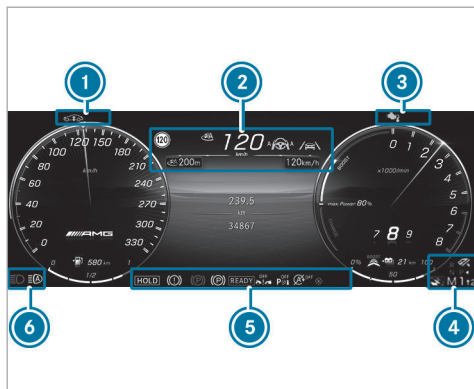











timedia system (→ page 12). You can also activate or deactivate ESP® using the steering wheel button or via the MBUX multimedia system (→ page 17).

Overview of status displays on the driver's display

The status displays for the driving and driving safety systems can be found in display sections 1 to 4.



-  Pedestrian detection (only on assistant display)
-  Active Parking Assist is available
-  Active Parking Assist has detected a parking space
-  Parking Assist PARKTRONIC switched off
-  Cruise control
-  Active Distance Assist DISTRONIC

-  Specified distance for Active Distance Assist DISTRONIC
-  Active Brake Assist switched off
-  Active Brake Assist impaired or not functioning
-  Active Steering Assist
-  Active Lane Change Assist
-  Active Lane Keeping Assist
-  Active Blind Spot Assist (only on assistant display)
-  ECO start/stop function
-  HOLD function
-  Adaptive Highbeam Assist
Adaptive Highbeam Assist Plus
-  Active Stop-and-Go Assist
-  Slippery road surface warning

Vehicles with Traffic Sign Assist: detected instructions and traffic signs

AMG TRACK PACE

Function of AMG TRACK PACE

i This function is an on-demand feature and can be activated via Mercedes me after you purchase your vehicle. The Digital Operator's Manual contains further information on Mercedes me and on-demand features.

With AMG TRACK PACE, the driving characteristics on race tracks can be analyzed and optimized. You can drive previously saved race tracks (e.g. Hockenheimring), or record and save new tracks. The driven lap times are stored for every track. These can be analyzed and compared with other lap times to achieve the best possible race results. Additionally, acceleration and braking procedures can be measured and stored.



Note: Use AMG TRACK PACE only on closed-off routes outside the public traffic area. Adapt your driving style to your personal performance and environmental conditions. As the driver, you are solely responsible for driving your vehicle. Park your vehicle safely before operating the application.

Setting Track Race



Multimedia system:

↳ TRACK PACE ▶▶ Track Race

Recording a new track

- ▶ Select  **New Track**.
- ▶ Select  **Start Recording** at the desired starting point.
The track recording starts at this point.



During track recording, sectors can be set to divide up the track.

- ▶  Select **Set Sector**.
- ▶ Select  **Stop Recording** to end track recording or cross the starting line again.
- ▶ Confirm the prompt with **Yes**.
- ▶ Select the weather.
- i** The temperature is determined automatically.
- ▶ Enter a name.
- ▶ Press **OK** to confirm.
The track is saved under the name entered.

Searching by track name



- ▶ Select  **Search**.
- ▶ Enter the track name.
Tracks with the searched name are displayed.

Measuring time on a saved track

- ▶  Select **All tracks**.
- ▶ Select the desired track.
- ▶ Select .
- ▶ Select **Start Time Recording** if you are already at the starting line.

or

- ▶ Select **Navigate to** for navigation to the starting line.
Timing begins automatically when the starting line has been crossed.

- i** When  is selected, the track display can be switched to AR. In addition, it is possible to switch to the telemetry display by selecting .
- ▶ Select  **Stop timing** to end timing.

- ▶ Confirm the prompt with **OK**.
- ▶ Select the weather.
- ▶ Select **Yes** to save the times driven for this track.

Showing readings during Track Race

The following readings can be shown:

- Tire temperature
- Miniature map
- Sector overview
- Engine data
- G-force display
- Lap overview

- ▶ Select  **Start Time Recording** .

- ▶ Select  .

- ▶ Drag the desired display from the grid on the left or right edge of the central display. The readings are shown during the Track Race.

By selecting  on the active display, you can deactivate this.

Displaying the analysis

- ▶  Select **All tracks**. An overview of all the driven tracks appears.

- ▶ Select a track.
- ▶ Select a session.

The following data are displayed:

- Lap and sector times
- Average and top speed
- Driver
- Vehicle
- Date
- Weather
- ▶ Select **Add Recording** to use a different session as a reference value.
- ▶ Select  to return to the overview.
- ▶ Select **Diagram**.

- ▶ Set the desired parameters. The analysis is displayed.

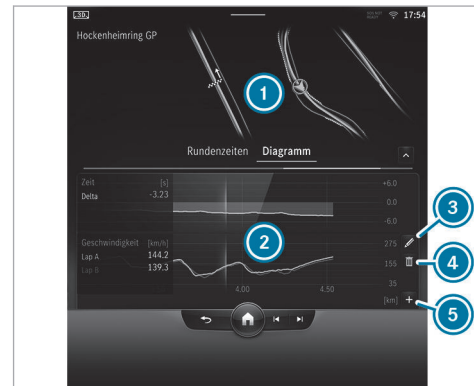



- ① Lap overview
- ② Parameter overview
- ③ Editing parameters
- ④ Deleting parameters
- ⑤ Adding new parameters

- i** The following values can be set for the parameters, for example:
- speed
 - Longitudinal/lateral acceleration
 - Steering angle
 - Engine speed
 - Engine oil/tire temperature



Based on the analysis, you can check and optimize the driving behavior for any position on the track.

Exporting tracks (USB)

- ▶ Select  **Tracks**.
An overview of all stored tracks appears.
- ▶ Select the desired track.
- ▶ Select options  for the desired track.
- ▶ Select **Export Track to...**
The selected track can be exported to a USB storage device connected to the vehicle.

Editing tracks and recordings

- ▶ Select  **Tracks**.
- ▶ Select the desired track.

- ▶ Select options  for the desired track.
 - ▶ Select **Rename** or **Delete**.
- or
- ▶ Select a track.
 - ▶ Highlight the desired recording.
 - ▶ Select  options.
 - ▶ Select **Export to...** or **Delete**.

Setting Drag Race

Multimedia system:

 **TRACK PACE** ▶▶ **Drag Race**

Measuring acceleration

- ▶ Select  **Drag race options**.
- ▶ Select **Acceleration**.
- ▶ Set a starting speed or select **Automatic**.
Measurement begins as soon as the specified starting speed has been reached.
- ▶ Set a target speed.
Measurement stops as soon as the specified target speed has been reached.

- ▶ Start off and begin the measurement.
Measurement begins when the vehicle accelerates.

Measurement can be stopped early by interrupting the acceleration procedure.

Quarter mile race

- ▶ Select  **Drag race options**.
- ▶ Select **Quarter Mile**.
- ▶ Set a target distance.
Measurement stops as soon as the specified target distance has been reached.
- ▶ Start off and begin the measurement.
Measurement begins when the vehicle accelerates. Timing runs until the target distance or a maximum of one mile has been traveled.

Measurement can be stopped early by interrupting the acceleration procedure.

Measuring braking

- ▶  **Drag Race options**
- ▶ Select **Braking**.
- ▶ Set a starting speed or select **Automatic**.

- ▶ Start off and begin the measurement.
- ▶ Brake to a stop. Measurement is incremental, in steps of 6 mph (10 km/h) to a stop. If the braking procedure is started e.g. at a speed of 98 mph (157 km/h), measurement starts as soon as 93 mph (150 km/h) has been reached

Storing and calling up measured values

If measurement is completed or canceled, a prompt appears asking whether the measurement should be saved.

- ▶ Confirm the prompt with **OK** to save.

Calling up saved measurements

- ▶  Select **History**.
- ▶ Select **Acceleration**, **Quarter Mile** or **Braking**.
- ▶ Select a measurement. The desired measurement is displayed in detail.

or

- ▶ Delete a measurement.

Calling up the telemetry display

Multimedia system:

- ▶  **TRACK PACE** ▶▶ **Telemetry**

The telemetry display shows current vehicle data as a digital value and as a diagram. Up to four parameters can be selected to be shown on the display.

For example:

- Engine speed
 - Wheel angle
 - Speed
 - Steering angle
- ▶ Set the desired parameters.
 - ▶ Set the time period. The set parameters will be evaluated in the diagram for the selected time period.

Configuring AMG TRACK PACE

Requirements

To connect a mobile device to the TRACK PACE app:

- The TRACK PACE app is installed on the mobile device.
- The mobile device is connected to the multimedia system via Wi-Fi.

Multimedia system:

- ▶  **TRACK PACE** ▶▶ 

Connect mobile device via the TRACK PACE app

The TRACK PACE app makes it possible to record videos and to synchronize them with stored tracks.

- ▶ Select **TRACK PACE App**.
- ▶ Select **Authorize a New Device**.
- ▶ Start the TRACK PACE app on the device to be connected.
- ▶ Select **Next** and confirm the authorization prompt. A four-digit code will be shown on the central display.
- ▶ Enter the code on your smartphone. The device will be authorized.

De-authorizing the mobile device

- ▶ Select **TRACK PACE App**.
- ▶ Select a device.
- ▶ Confirm the message prompt with Yes.
The device will be de-authorized.

Setting the TRACK PACE display on the head-up display and driver's display

- ▶ Select **IC and HUD Contents**.
- ▶ Activate or deactivate the desired content.
The content on the head-up display and the driver's display will be adapted.
- ⓘ For further information on the head-up display .
- ⓘ Further information about the driver's display .

Setting acoustic feedback

- ▶ Select **Acoustic Feedback**.
A scale with values from 0 to 10 will be shown.
- ▶ Select a setting.

Displaying statistics

- ▶ Select **TRACK PACE Statistics**.
Statistics on the current user profile will be displayed.
The following data will be displayed:
 - Driving time
 - Track driven
 - Recorded tracks
 - Recorded track races
 - Laps recorded
 - Recorded drag races
 - Top speed

Activating the ambient light

If this function is active, the vehicle interior will be lit in red or green depending on delta time.

- ▶ Select **Ambient Light**.
- ▶ Activate or deactivate the function.

Adjusting the dashcam

If the vehicle is equipped with a dashcam, it can be used in AMG TRACK PACE.

- ▶ Select **Dashcam**.
- ▶ Select **Track Race** or **Drag Race** and activate **Activate Recording**.
- ▶ You can set which overlay is to be used in the recorded video under **Video Overlay Content**.

Notes on the care of tailpipes

⚠ WARNING Risk of burns from the tailpipe and tailpipe trims

The exhaust tailpipe and tailpipe trims can become very hot. If you come into contact with these parts of the vehicle, you could burn yourself.

- ▶ Always be particularly careful around the tailpipe and the tailpipe trims and supervise children especially closely in this area.
- ▶ Allow vehicle parts to cool down before touching them.

Observe the following notes in order to prevent damage to the vehicle:

- Clean the tailpipes with a cleaning agent recommended for Mercedes-Benz, especially in the winter and after washing the vehicle.
- Do not use acidic cleaning agents.

Removing the warning triangle

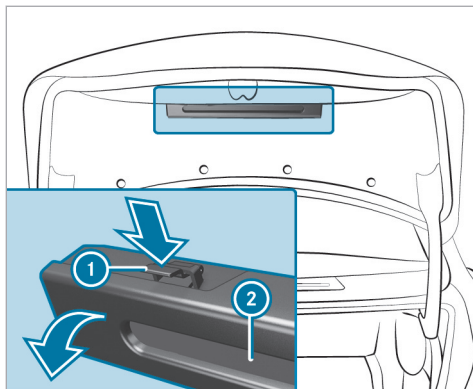

- ▶ Push both sides of warning triangle holder ① in the direction of the arrow and open it.
- ▶ Remove warning triangle ②.

The warning triangle is located in the trunk lid.

32 Wheels and tires

Changing a wheel

- ▶ Be sure to also observe the notes on changing a wheel in the Operator's Manual of your vehicle.

Operating fluids

Fuel

Information on fuel quality for Mercedes-AMG vehicles

Observe the information on operating fluids in the vehicle Operator's Manual.

! NOTE Damage caused by the wrong fuel

Even small amounts of the wrong fuel could result in damage to the fuel system, the engine and the emission control system.

- ▶ Only refuel with low-sulfur spark-ignition engine fuel.

This fuel may contain up to 10% ethanol by volume. Your vehicle is suitable for use with E10 fuel.

Never refuel with one of the following fuels:

- diesel
- Gasoline with more than 10% ethanol by volume, e.g. E15, E85, E100

- Gasoline with more than 3% methanol by volume, e.g. M15, M30, M85, M100
- Gasoline with additives containing metal

If you have accidentally refueled with the wrong fuel:

- ▶ Do not switch on the vehicle.
- ▶ Consult a qualified specialist workshop.

If the available fuel is not sufficiently low in sulfur, it may produce unpleasant odors.

Refuel using only premium-grade unleaded gasoline of at least 91 AKI/95 RON.

As a temporary measure, if the recommended fuel is not available, you may also use regular unleaded gasoline. When doing this, note the octane number on the vehicle on the information label on the fuel filler flap (see the vehicle Operator's Manual). Filling up with regular unleaded gasoline can reduce engine output and increase fuel consumption.

Never refuel using gasoline of an even lower RON.

! NOTE Premature engine wear through unleaded regular gasoline

Impairment of the longevity and performance of the engine.

If unleaded premium grade gasoline is unavailable and you have to refuel using unleaded regular gasoline:

- ▶ Only fill the fuel tank to half full with unleaded regular gasoline and refill as soon as possible with unleaded premium grade gasoline.
- ▶ Do not drive at the maximum design speed.
- ▶ Avoid sudden acceleration and engine speeds over 3000 rpm.

Further information on fuel is available at the following locations:

- At a gas station
- At a qualified specialist workshop
- **USA only:** on the <https://www.mbusa.com>

Tank content and fuel reserve (Mercedes-AMG vehicles)

Total fuel tank capacity

Model	
Mercedes-AMG C 43 4MATIC+	17.4 gal (66.0 liters)

Fuel tank reserve

Model	
Mercedes-AMG C 43 4MATIC+	1.9 gal (7.0 liters)

Engine oil quality and filling capacity (Mercedes-AMG vehicles)

Engine oil specification

Model	MB-Freigabe or MB-Approval
Mercedes-AMG C 43 4MATIC+ (Sedan)	229.71 ¹⁾
1) Recommended for the lowest possible fuel consumption (lowest SAE viscosity class in each case; observe possible restrictions of the approved SAE viscosity classes)	

To achieve the lowest possible fuel consumption, it is recommended to use the engine oil specifications marked in the table for the lowest SAE viscosity class. Observe any possible restrictions of the approved SAE viscosity classes.

Engine oil filling capacity

Model	Capacity
Mercedes-AMG C 43 4MATIC+ (Sedan)	6.3 US qt (6.0 liters)

The specified filling capacity refers to an oil change with the oil filter.

Coolant filling capacity (Mercedes-AMG vehicles)

Coolant

Mercedes-AMG C 43 4MATIC+ (Sedan)	Capacity
Engine cooling circuit (filling capacity with heating)	12.8 US qt (12.1 liters)
Cooling circuit (drive system)	7.5 US qt (7.1 liters)
Cooling circuit (high-voltage battery)	3.2 US qt (3.0 liters)

Coolant and PAG oil filling capacity (Mercedes-AMG vehicles)

Refrigerant filling capacity

Model	
Mercedes-AMG C 43 4MATIC+ (Sedan)	22.9 ± 0.4 oz (650 ± 10 g)

Filling capacity for PAG oil

Model	
Mercedes-AMG C 43 4MATIC+ (Sedan)	2.8 ± 0.4 oz (80 ± 10 g)

Vehicle data

Vehicle dimensions (Mercedes-AMG vehicles)

The heights specified may vary as a result of the following factors:

- Tires
- Load
- Condition of the suspension
- Optional equipment

Missing values were not available at time of going to print.

Vehicle dimensions

Mercedes-AMG C 43 4MATIC+ (Sedan)	
Vehicle length	188.6 in (4791 mm)
Vehicle width including exterior mirrors	80.0 in (2033 mm)
Vehicle height	57.2 in (1452 mm)
Wheelbase	112.8 in (2865 mm)
Turning radius	

Weights and loads (Mercedes-AMG vehicles)

Bear in mind that items of optional equipment increase the curb weight and reduce the payload. Vehicle-specific weight information can be found on the vehicle identification plate.

Maximum design speeds

The following values only apply to vehicles with the AMG Driver's Package.

The maximum design speed can differ from the stated figures in practice. It depends on the operating conditions, the optional equipment and the size of the tires.

Missing values were not available at time of going to print.

Maximum design speed

Sedan	
Mercedes-AMG C 43 4MATIC+	

Display messages

Vehicle

Display messages	Possible causes/consequences and ► Solutions
Electronic Rear Axle Differential Lock Inoperative	<ul style="list-style-type: none"> * The electronic locking differential has failed. <ul style="list-style-type: none"> ► Visit a qualified specialist workshop.
Electronic Rear Axle Differential Lock Currently Unavailable	<ul style="list-style-type: none"> * The electronic locking differential is overheated. <ul style="list-style-type: none"> ► Let the electronic locking differential cool down by driving defensively.

Driving systems

Display messages	Possible causes/consequences and ► Solutions
RACE START Not Possible See Operator's Manual	<ul style="list-style-type: none"> * Possible causes: <ul style="list-style-type: none"> • The activation conditions have not been fulfilled (→ page 18).
RACE START Canceled	<ul style="list-style-type: none"> * Possible causes: <ul style="list-style-type: none"> • You released the accelerator pedal during RACE START. • You depressed the brake pedal during RACE START. ► You can try RACE START again at the next start.

Display messages	Possible causes/consequences and ► Solutions
 <p data-bbox="195 339 458 391">Malfunction Drive at Max. 50 mph</p>	<p data-bbox="519 249 1123 308">* ► Do not drive at speeds greater than 50 mph (80 km/h). ► Consult a qualified specialist workshop.</p>
<p data-bbox="195 415 473 491">AMG Ride Control Function Limited See Operator's Manual</p>	<p data-bbox="519 415 1585 474">* The system is outside the operating temperature range or the on-board electrical system voltage is too low. Once the cause of the problem is no longer present, the system will be available again.</p> <div data-bbox="550 495 1696 674" style="border: 1px solid black; padding: 5px;"> <p data-bbox="559 503 1641 555">! NOTE The vehicle's suspension and damping behavior is restricted. The vehicle body may tilt heavily to the side during cornering.</p> <ul style="list-style-type: none"> <li data-bbox="559 570 772 591">► Drive on carefully. <li data-bbox="559 607 1077 627">► Reduce speed considerably before taking a bend. <li data-bbox="559 643 938 664">► Avoid sudden steering movements. </div> <p data-bbox="541 689 1058 783"> ► Drive on carefully. ► Reduce speed considerably before taking a bend. ► Avoid sudden steering movements. </p>

Warning and indicator lamps

Driving systems

Warning/indicator lamp	Possible causes/consequences and ► Solutions
 <p data-bbox="144 425 397 474">Suspension warning lamp (yellow)</p>	<p data-bbox="463 332 1160 381">* The yellow AMG adaptive sport suspension system warning lamp is lit. There is a malfunction in the AMG adaptive sport suspension system.</p> <p data-bbox="476 391 925 417">► Note the messages on the driver's display.</p>

Driving safety systems

Warning/indicator lamp	Possible causes/consequences and ► Solutions
	<p data-bbox="463 618 1169 667">* The yellow ESP® OFF warning lamps are lit while the vehicle is running. ESP® is deactivated.</p> <p data-bbox="476 677 1197 704">Other driving systems and driving safety systems may also be inoperative.</p> <div data-bbox="482 726 1646 767" style="background-color: #f0f0f0; padding: 5px;"> <p data-bbox="491 734 1151 761">▲ WARNING Risk of skidding when driving with ESP® deactivated</p> </div> <p data-bbox="491 774 1517 801">ESP® does not act to stabilize the vehicle. The availability of further driving safety systems is also limited.</p> <p data-bbox="491 812 707 838">► Drive on carefully.</p>

Warning/indicator lamp	Possible causes/consequences and ► Solutions
	<ul style="list-style-type: none"> ► Deactivate ESP® only for as long as the situation requires. If ESP® cannot be activated, ESP® is malfunctioning. ► Have ESP® checked immediately at a qualified specialist workshop. ► Observe the notes on deactivating ESP® (→ page 15).
	<p>* ESP® SPORT is activated while the vehicle is running. When ESP® SPORT is activated, ESP® will stabilize the vehicle only to a limited extent.</p> <p>⚠ WARNING Risk of skidding if ESP® SPORT is used incorrectly</p> <p>When you activate ESP® SPORT, there is an increased risk of skidding and having an accident.</p> <ul style="list-style-type: none"> ► Activate ESP® SPORT only in the circumstances described below. ► Observe the notes on activating ESP® SPORT(→ page 15).

A		B		Display (driver's display)	
AMG adaptive sport suspension system		Boost pressure, current (driver's display).....	23	Overview of displays.....	23
Selecting the suspension setting.....	19	C		Display messages	
Suspension.....	19	Care		 Malfunction Drive at Max. 50	
AMG DYNAMIC SELECT		Tailpipes.....		mph.....	
Setting drive programs.....	12	30		AMG Ride Control Function Limited	
AMG Real Performance Sound.....	10	Changing a wheel		See Operator's Manual.....	
AMG steering wheel buttons		Installing a new wheel.....		Electronic Rear Axle Differential Lock	
Setting.....	8	Removing a wheel.....		Currently Unavailable.....	
AMG steering-wheel buttons		32		Electronic Rear Axle Differential	
Function.....	8	Climate control		Lock Inoperative.....	
AMG TRACK PACE		Filling capacity for refrigerant and		RACE START Canceled.....	
Configuring.....	28	PAG oil.....		RACE START Not Possible See Opera-	
Drag Race.....	27	35		tor's Manual.....	
Function.....	25	Cockpit		Drag Race	
Telemetry display.....	28	Dashboard overview.....		Setting.....	
Track Race.....	25	4		Drive program display.....	
Automatic transmission		Coolant		Drive programs	
Drive programs.....	10	Capacity.....		AMG DYNAMIC SELECT.....	
DYNAMIC SELECT button.....	10	34		Selecting.....	
Manual gear shifting.....	13	D			
Oil temperature (driver's display).....	23	Dashboard			
Steering wheel paddle shifters.....	13	Cockpit overview.....			
		4			
		DIRECT SELECT lever			
		Manual gearshifting.....			
		13			

- | | | | | | |
|--|----|---|--------|------------------------------------|----|
| Driver display | | Engine oil | | G | |
| Track Pace menu..... | 22 | Capacity..... | 34 | G-meter, Accelerometer..... | 23 |
| Driver's display | | MB-Freigabe or MB-Approval..... | 34 | Gasoline..... | 33 |
| Operating..... | 21 | Quality..... | 34 | Gearshift | |
| Status displays..... | 23 | Temperature (driver's display)..... | 23 | Automatic transmission..... | 13 |
| Driving safety system | | Engine oil temperature (driver's display)..... | 23 | Manual..... | 13 |
| ESP® (Electronic Stability Program)..... | 15 | Engine output, current (driver's display)..... | 23 | Glide mode..... | 14 |
| DYNAMIC SELECT | | Engine sound..... | 10 | | |
| Configuring drive program I..... | 12 | ESP® | | I | |
| Drive program display..... | 11 | Adjusting (steering-wheel button)..... | 16 | Individual drive program | |
| Drive programs..... | 10 | ESP® SPORT..... | 15 | Configuring..... | 12 |
| Function..... | 10 | Function..... | 15 | Installing | |
| Selecting the drive program..... | 11 | Setting..... | 17, 18 | Tires/wheels..... | 32 |
| | | | | | |
| E | | F | | M | |
| E10..... | 33 | Fuel | | Manual gearshifting | |
| ECO start/stop button | | E10..... | 33 | Activating/deactivating..... | 14 |
| Automatic engine start/stop..... | 9 | Gasoline..... | 33 | Maximum speeds..... | 35 |
| ECO start/stop function | | Gasoline quality..... | 33 | MBUX multimedia system | |
| Switching off/on..... | 9 | Reserve..... | 34 | Drive programs..... | 12 |
| Electronic Stability Program..... | 15 | Sulfur content..... | 33 | Menus (driver display) | |
| Emotion Start..... | 9 | Tank content..... | 34 | Track Pace..... | 22 |
| | | Fuel reserve..... | 34 | | |

Menus (driver's display)

Sport..... 23

O**Operating fluids**

Gasoline..... 33

Operator's manual..... 6

P**Paddle shifters**

Steering wheel paddle shifters..... 13

Programs..... 10

R**RACE START**

Activating..... 18

Activation conditions..... 18

Information..... 18

Racetrack mode

AMG steering-wheel buttons..... 8

Reserve

Fuel..... 34

Rocking free..... 13

S**Seat belts**

Reduced protection..... 7

Selecting a gear..... 13

Selecting a sound characteristic (steering-wheel button)..... 10

Shifting

Automatic transmission..... 13

Manual..... 13

Steering wheel paddle shifters..... 13

Sound

AMG Real Performance Sound..... 10

Start/stop button

Emotion Start..... 9

Steering wheel paddle shifters..... 13

Stop and go

ECO start/stop function..... 9

Sulfur content..... 33

Suspension

AMG adaptive sport suspension system... 19

Selecting the suspension setting..... 19

T**Tailpipes**

Care..... 30

Tank content

Fuel..... 34

Reserve..... 34

Technical data

Maximum speeds..... 35

Vehicle dimensions..... 35

Telemetry display

Calling up..... 28

Tires

Installing..... 32

Removing..... 32

Torque (driver's display)..... 23

Touch Control

Driver's display..... 21

Track Pace

Menu (driver display)..... 22

Track Race

Setting..... 25

V

vehicle

Emotion Start.....	9
Equipment.....	6
Rocking free.....	13

Vehicle data

Maximum speeds.....	35
Turning circle.....	35
Vehicle height.....	35
Vehicle length.....	35
Vehicle width.....	35
Weights.....	35
Wheelbase.....	35

Vehicle dimensions.....	35
--------------------------------	-----------

Vehicle equipment.....	6
-------------------------------	----------

W

Warning triangle.....	31
------------------------------	-----------

Warning/indicator lamp

 Suspension warning lamp (yellow)..	38
--	----

Wheels

Mounting.....	32
Removing.....	32

